

The anticoagulant function of coagulation factor V

Thomas J. Cramer; Andrew J. Gale

Department of Molecular and Experimental Medicine, The Scripps Research Institute, La Jolla, California, USA

Summary

Almost two decades ago an anticoagulant function of factor V (FV) was discovered, as an anticoagulant cofactor for activated protein C (APC). A natural mutant of FV in which the R506 inactivation site was mutated to Gln (FV_{Leiden}) was inactivated slower by APC, but also could not function as anticoagulant cofactor for APC in the inactivation of activated factor VIII (FVIIIa). This mutation is prevalent in populations of Caucasian descent, and increases the chance of thrombotic events in carriers. Characterisation of the FV anticoagulant effect has elucidated multiple properties of the anticoagulant function of FV: 1) Cleavage of FV at position 506 by APC is required for anticoagulant function. 2) The

C-terminal part of the FV B domain is required and the B domain must have an intact connection with the A3 domain of FV. 3) FV must be bound to a negatively charged phospholipid membrane. 4) Protein S also needs to be present. 5) FV acts as a cofactor for inactivation of both FVa and FVIIIa. 6) The prothrombotic function of FV_{Leiden} is a function of both reduced APC cofactor activity and resistance of FVa to APC inactivation. However, detailed structural and mechanistic properties remain to be further explored.

Keywords

Activated protein C, anticoagulant, APC resistance, factor V, protein S

Correspondence to:

Andrew J. Gale, PhD
The Scripps Research Institute, MEM-286
10550 North Torrey Pines Road
La Jolla, CA, 92037, USA
Tel.: +1 858 784 2177, Fax: +1 858 784 2054
E-mail: agale@scripps.edu

Financial support:

This study was supported by The Stein Endowment Fund.

Received: June 24, 2011

Accepted after major revision: October 24, 2011

Prepublished online: November 24, 2011

doi:10.1160/TH11-06-0431

Thromb Haemost 2012; 107: 15–21

Introduction

In 1947 Paul A. Owren discovered factor V (FV) and described it as a procoagulant protein that activates factor X (1). Over the following decades the function of FV was further investigated and redefined as the procoagulant non-enzymatic cofactor of activated factor X (FXa) (► Fig. 1A). Readers interested in these developments are referred to this review (2), which describes the history of FV up to and including the discovery of APC resistance in 1993 (3). A common cause for APC resistance was found in a mutation of FV, Arg at position 506 to Gln (R506Q-FV, also known as FV_{Leiden}), which abolished the R506 cleavage site for the anticoagulant serine protease activated protein C (APC) (4). Loss of this cleavage site severely reduced the inactivation of the procoagulant form of FV, activated FV (FVa), and resulted in shorter clotting time. Within one year an additional function was attributed to FV, as anticoagulant cofactor for APC (5). Cleavage of non-activated FV at position 506 was required for the anticoagulant function to be expressed, and therefore R506Q-FV did not have this anticoagulant function, further contributing to the thrombogenic phenotype in patients who carry this mutation. Since its discovery, the anticoagulant function of FV has been further characterised, and this review will summarise these developments.

The function of anticoagulant APC

APC is the central serine protease in the anticoagulant reactions. APC inactivates factors Va and VIIIa by limited proteolysis (► Fig. 1B), cleaving FVa at positions R306, R506, and R679 (6), and FVIIIa at positions R336 and R562 (7), resulting in inhibition of thrombin generation. Cleavage of FVa at R306 (slow) results in complete inactivation of the molecule, cleavage at R506 (fast) yields a partially active intermediate (8), and cleavage at R679 (~1,000-fold slower than R306 cleavage [8]) has thus far not been attributed any physiological significance. FVIIIa is quickly inactivated by spontaneous dissociation of the A2 domain (9, 10), and by APC. Cleavage of FVIIIa by APC at R562 correlates well with loss of FVIIIa activity, and cleavage at R336 may stimulate A2 domain dissociation (7). In a FVIIIa variant in which spontaneous A2 domain dissociation was prevented with an engineered disulfide bridge, cleavage at R336 (fast) partially inactivated FVIIIa, and cleavage at R562 (slow) resulted in complete inactivation (11).

Similar to other coagulation serine proteases, APC has a cofactor that enhances its proteolytic activity: protein S. This non-enzymatic cofactor enhances FVa and FVIIIa inactivation by APC, and has been well characterised in these reactions. Protein S stimulates APC cleavage of FVa at R506 1– to 5-fold, and cleavage at R306 20– to 30-fold (12, 13). Binding of protein S to APC results in a change of conformation of APC, which apparently brings the active site

closer to the membrane (14, 15). For FVa inactivation this may mean that the active site is now better positioned for cleavage of FVa at R306, which could explain why protein S stimulates cleavage at this site more than cleavage at R506. It is, however, not known if R306 is positioned closer to the membrane than R506. Therefore it was recently disputed that lowering the active site of APC specifically stimulated R306 cleavage. Furthermore, protein S also enhances cleavage at R506, which also argues against a selective effect towards R306 cleavage (16).

In FVIIIa inactivation, in the absence of A2 domain dissociation, protein S stimulates cleavage at R336 approximately six- to eight-fold, and cleavage at R562 8- to 60-fold (11, 17), although reaction rates of FVIIIa inactivation are dependent on the experimental conditions and reagents used. FVIIIa inactivation by APC when the A2 domain can dissociate showed slower cleavage rates, but the inactivation cleavages showed a similar pattern. Under these conditions cleavage rates may be underestimated due to the dissociation of the A2 domain (18). However, it is clear that in FVa and FVIIIa the slowest cleavages (R306 and R562, respectively) are enhanced more by protein S than the faster cleavages (R506 and R336, respectively) (11–13, 18).

The importance of the anticoagulant PC system is illustrated by an increased risk of venous thrombosis associated with heterozygous PC deficiency and severe thrombotic disease due to homozygous PC deficiency (19, 20). Furthermore, it is interesting that the concentration of thrombomodulin, which is of vital importance for PC activation, varies from 0.15 nM in the large vasculature to 500 nM in the microvasculature (21), the latter being the vessels where the majority of coagulation takes place, thereby locating PC activation to the site of active coagulation.

APC resistance

With the discovery of APC resistance by Dahlbäck et al. in 1993 (3) a whole field of new research opportunities opened up, and was followed by a true explosion of publications on the subject. The APC resistance test that was developed initially was based on an activated partial thromboplastin time (APTT) clotting assay, measuring the clotting time of patient plasma in the presence and in the absence of APC. In approximately 20–60% of venous thrombosis patients APC failed to prolong the plasma clotting time, and these patients were therefore called APC resistant (22–25). Shortly after its discovery, APC resistance was shown to strongly correlate with the G1691A mutation in the FV gene (4, 26), which was found in over 90% of individuals with inherited APC resistance (4, 27). This mutation results in a change of Arg to Gln at position 506, which abolishes the APC cleavage site at position 506 and results in a 10- to 20- fold slower inactivation of FVa (8, 28). Addition of purified wild-type FV to APC resistant plasma returned the APC sensitivity to normal (5), and it was therefore hypothesised that FV may be an anticoagulant cofactor for APC. This was confirmed in purified assays where FV enhanced APC/protein S-mediated inactivation of FVIIIa (29).

Individuals heterozygous for the G1691A mutation have an approximately five-fold increased risk for deep venous thrombosis, whereas in homozygous individuals the risk increase has been estimated at 80-fold (24, 30). The impact of FV anticoagulant function on thrombosis risk may be demonstrated by the very rare condition of pseudo-homozygous R506Q-FV, in which one allele carries the G1691A mutation, and the other allele carries a null mutation. Consequently, these individuals only have 50% of FV antigen in their blood, all of which is R506Q-FV (31–37). Normally heterozygous factor V deficiency is a risk for bleeding (38). Therefore, this heterozygous deficiency might be expected to counteract the thrombotic risk of heterozygous R506Q-FV. But in fact, pseudo-homozygosity results in a phenotype that is indistinguishable from homozygous R506Q-FV patients. In thrombin generation assays, pseudo-homozygous patient plasma may even be more thrombogenic than homozygous R506Q-FV patient plasma because of reduced plasma levels of tissue factor pathway inhibitor (39). Experiments measuring the APC sensitivity ratio of FV-deficient plasma, reconstituted with various combinations of normal FV and R506Q-FV showed that the APC resistance was not dependent on the absolute amount of R506Q-FV, but on the relative amount of normal FV (36, 37, 40). This is because this normal FV is required for normal anticoagulant function of APC because of its anticoagulant cofactor activity. It is therefore likely that the loss of this anticoagulant FV function in pseudo-homozygous APC resistance contributes to a more thrombophilic phenotype demonstrating the physiologic relevance of the FV anticoagulant cofactor function (36, 37, 40).

G1691A appears to be a relatively young mutation in the human genome, as it is only found in European Caucasians, and not in other populations such as Asians, Africans, natives of Australia and the Americas, and the Inuit peoples. This suggests that the mutation first occurred after the European-Asian split that followed the 'out-of-Africa exodus', and has been estimated to be approximately 21,000 years old (41). Therefore most studies were aimed at this particular group, until the question was raised whether mutations at the other APC cleavage sites of FV also influenced the FV anticoagulant cofactor effect.

Naturally occurring mutants of the APC cleavage site R306 (FV_{Hong Kong} R306G [42] and FV_{Cambridge} R306T [43]) result in only mild APC resistance (44–46). Mutation at the third APC cleavage site in FV, at R679, has not been associated with decreased APC sensitivity (45). However, a recently discovered mutation E666D in a Chinese family with a history of venous thrombosis did show a slight APC resistance, and was suggested as a mild risk factor for thrombosis (47). Possibly the observed APC resistance was due to inhibition of cleavage at R679, however this is currently only speculation and remains to be confirmed.

Another FV mutant that results in the APC resistance phenotype is FV_{Liverpool} (I359T-FV) (48). This mutation can cause early onset of severe thrombophilia, and its functional characterisation is discussed further below. For a full history of the discovery of APC resistance, we would like to direct the reader to an excellent review on this topic (49). We will now focus on the mechanisms of the FV anticoagulant cofactor effect.

Mechanism of FV anticoagulant cofactor function

In the setting of an APTT assay, in which plasma clotting time is sensitive to both FVa and FVIIIa inactivation, it has been suggested that approximately 50% of R506Q-FV mediated APC resistance is due to the R506Q-FVa molecule being partially resistant to inactivation by APC, and approximately 50% is due to the absence of the FV cofactor effect for APC (40). This means that the absence of FV anticoagulant cofactor activity may be responsible for up to 50% of the increased risk of thrombotic events in homozygous R506Q-FV carriers.

FV was first described to stimulate the anticoagulant function of APC by acting as a cofactor for APC inactivation of FVIIIa in the presence of protein S (29, 50) (► Fig. 1B). Protein S and FV together stimulated FVIIIa inactivation rates approximately 11-fold (51). This was the consequence of stimulation of FVIIIa cleavage at R336 by APC/protein S in the presence of FV by three- to four-fold, and stimulation of cleavage at R562 by seven- to eight-fold (11, 17). The APC resistant R506Q-FV, however, did not enhance FVIIIa inactivation (51, 52), which suggested that cleavage at the 506 position was required for the APC-cofactor effect of FV. This further explained why R506Q-FV caused APC resistance, a procoagulant phenotype, as R506Q-FVa is inactivated more slowly than wild-type FVa, and R506Q-FV lacks the anticoagulant cofactor activity for APC.

Recent experiments showed that anticoagulant FV also contributes to APC-mediated inactivation of FVa (► Fig. 1B). This was demonstrated in plasma based clotting assays in which the clotting time was sensitive to only FVa inactivation, and not to FVIIIa inactivation. In this study titrations of FV into FV-deficient plasma resulted in increased clotting time and increased APC sensitivity ratio at higher FV concentrations, which suggested a concentration dependent anticoagulant effect of FV in a plasma-based clotting assay that measured FVa activity specifically (53). This suggests that FV anticoagulant function is a significant contributor to the APC inactivation of FVIIIa and of FVa. Given that FVIIIa spontaneously inactivates via dissociation of subunits, some re-

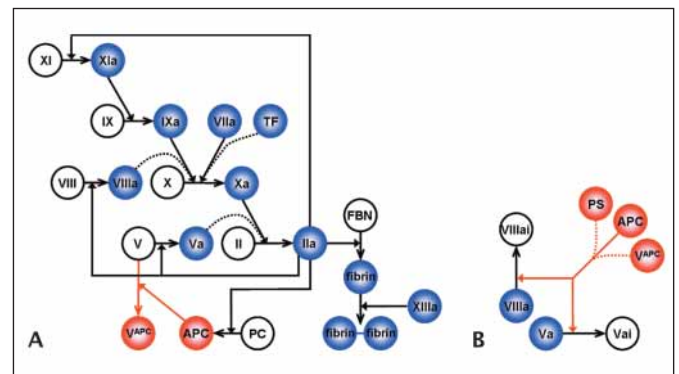

Figure 1: Abbreviated scheme of the coagulation reaction. A) Procoagulant reaction. B) APC-mediated anticoagulant reaction. Blue: procoagulant. Red: anticoagulant. TF: tissue factor. FBN: fibrinogen. V^{APC}: FV cleaved at R506 by APC. PS: protein S. Dashed line indicates a cofactor.

searchers have suggested that APC inactivation of FVIIIa may not be physiologically relevant (50, 54). This would imply that FV APC cofactor activity may be more important for physiologic FVa inactivation than for physiologic FVIIIa inactivation. However, the FV anticoagulant cofactor effect for FVa inactivation by APC has only been shown in a plasma milieu and, due to the complexity of a plasma environment, will need to be confirmed in other settings.

A unique cleavage sequence is required to generate anticoagulant FV

Because both single chain FV and the procoagulant FVa can be cleaved by APC, it is important to distinguish between the consequences of the cleavages of these two APC substrates. Single chain FV is activated by thrombin through proteolysis at positions R709 at the end of the A2 domain, R1018 in the B domain, and R1545 at the end of the B domain (► Fig. 2). This results in removal of the B domain and formation of the procoagulant hetero-

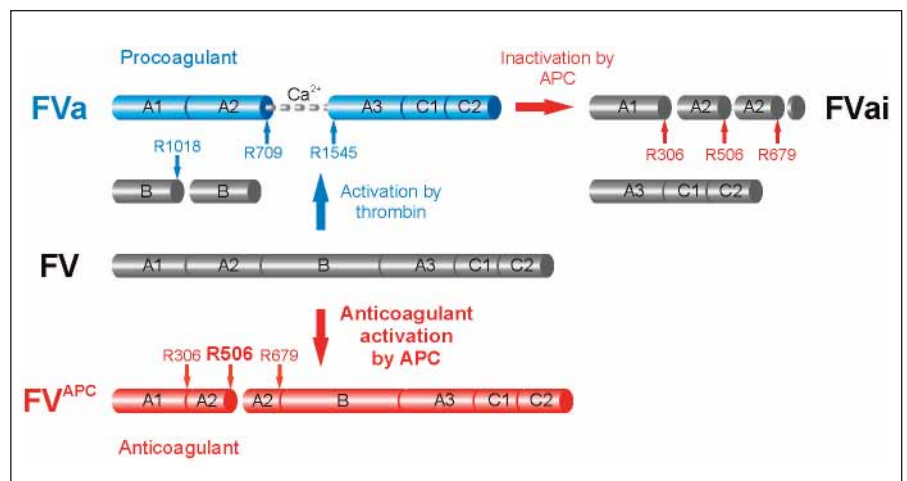

Figure 2: Anticoagulant activation of FV by APC, and procoagulant activation of FV by thrombin. Blue: procoagulant FV structures and cleavages. Red: anticoagulant FV structures and cleavages. Grey: non-active FV structures. FV^{APC}: anticoagulant FV that is a cofactor for APC. FVai: inactivated FVa.

dimer FVa, consisting of a heavy chain (A1 and A2 domains) and a light chain (A3, C1 and C2 domains), which is stabilised by calcium ions. This procoagulant FVa molecule can subsequently be inactivated by APC through proteolysis at positions R306, R506 and R679, resulting in inactivated FVa (FVai). Single-chain FV can also be cleaved by APC at these same positions, creating the anticoagulant form of FV, referred to in ►Figure 2 as FV^{APC}. The anticoagulant form of FV acts as a cofactor for APC and protein S in the inactivation of FVa and FVIIIa. Cleavages at R306 and R679, do not affect the anticoagulant function of FV confirming that the R506 cleavage is critical for FV anticoagulant activity (50, 52). Furthermore, cleavage of the intact FV molecule at R306 appears to be faster than the cleavage at R506 (6, 55). This suggests that anticoagulant FV may already be fully proteolysed by APC when it acts as a cofactor for APC (50). Interestingly, cleavage of FV by APC does not seem to be influenced by protein S (50). How these cleavages alter the FV molecule and allow for the FV anticoagulant function to be expressed is currently not known.

The C-terminal part of the B-domain is mandatory for anticoagulant function

FV anticoagulant function requires that the C-terminal end of the B domain is present and attached to the A3 domain in the light chain. When FV is cleaved at position R1545 by thrombin during activation (►Fig. 2), the B domain is separated from the light chain and the anticoagulant function of FV is permanently lost. The other thrombin cleavages in FV, at R709 and R1018, do not influence the FV anticoagulant effect (29, 50, 56). A FV mutant with the whole B domain deleted (FV Δ 710–1545) lost all APC cofactor activity. However, FV with the C-terminal part of the B domain present (FV Δ 710–1476) retained nearly full APC cofactor activity, which suggests that residues 1476–1545 are required for the anticoagulant cofactor effect of FV (56). The C-terminus of the B domain (287 residues) contains at least 20 repeats of a nine amino acid sequence, is very acidic, and has 8 potential N-linked glycosylation sites. Section 1476–1545 is still very acidic with 16 D/E residues out of 70 total, and has one potential glycosylation site, at N1531 (57, 58). Therefore, this may be (part of) a binding site on anticoagulant FV in an APC/protein S/FV-complex.

The presence of protein S is absolutely required for the anticoagulant function of factor V

Another requirement of the FV anticoagulant cofactor activity is the presence of protein S (29, 50). In the absence of protein S, FV has virtually no cofactor activity for APC. It is therefore important to closely examine the structure and known interactions of protein S in this system, which may elucidate part of the mechanism by which FV exerts its anticoagulant effect.

Protein S consists of a Gla domain, a thrombin sensitive region (TSR), four EGF domains, and a sex hormone-binding globulin (SHBG) domain (59, 60). A binding site for protein S on APC has been located to residues 35 to 39 in the Gla domain of APC, with L38 as most important residue (61–63). An important binding site for APC on protein S was found in the region around residue D95 in the EGF1 domain of protein S (64). Other studies have suggested that the protein S Gla domain (65), thrombin sensitive region (66–69), the EGF1 domain (66, 68, 70), EGF2 domain (71), and even EGF3 and EGF4 (68, 72) are also involved in the APC–protein S interaction. These studies imply an extended binding site between protein S and APC.

Protein S is found in plasma at approximately 350 nM, of which approximately 60% is bound to the β -chain of C4b-binding protein (C4BP) (73, 74). This is a very high affinity interaction that is calcium-dependent (73, 75), and involves the SHBG-like domain of protein S (76–78). Free (unbound) protein S is the primary anticoagulant cofactor for APC. However, C4BP-bound protein S does still enhance cleavage of FVa at residue R306 ~10-fold, but it also inhibits cleavage at R506 three- to four-fold, resulting in an overall six- to eight-fold reduced FVa inactivation rate compared with APC bound to free protein S (79). Additionally, C4BP-bound protein S retains full APC cofactor activity in the inactivation of FVIIIa in the absence of FV (80).

However, C4BP-bound protein S does not support FV anticoagulant function (51). This may be because the SHBG-like domain of protein S is necessary for the FV anticoagulant activity (81, 82). A truncated protein S variant in which the SHBG-like domain was absent ('mini-protein S') expressed normal APC cofactor activity in purified FVa and FVIIIa inactivation assays, but did not support the APC cofactor activity of FV in the FVIIIa inactivation reaction (80, 81). Also, replacement of the protein S SHBG-like domain with the homologous domain of growth arrest-specific protein 6 (Gas6) resulted in the abolition of the FV cofactor activity (82). These studies suggest that the anticoagulant form of FV interacts with the SHBG-like domain of protein S. To speculate on this, it is conceivable that cleavage of FV at R506 opens up a binding site for the SHBG-like domain of protein S, that may involve the negatively charged C-terminal section of the FV B domain, and possibly other regions on FV that have not yet been identified.

The glycosylation status of FV may affect the anticoagulant function

The glycosylation status of FV may also play a role in the anticoagulant function. There are 37 potential glycosylation sites on FV, nine on the heavy chain, 25 in the B domain, and three in the light chain (57, 58, 83). Partial removal of N-linked carbohydrates enhanced FV susceptibility to APC cleavage, and increased the APC sensitivity ratio in an APTT assay when added to FV-deficient plasma. The increase of APC sensitivity ratio may be explained by either an increase in FV anticoagulant activity, or an increase of FV proteolytic inactivation by APC, or both. Whether FVa is in-

deed more sensitive to APC after mild deglycosylation is at this point not clear, as contradictory results have been published (84, 85). To date, the function of individual N-linked carbohydrates in FV anticoagulant cofactor function has not been investigated.

FV is found in two forms in plasma which differ in the glycosylation status at N2181 in the C2 domain, and are designated FV₁ (with N2181 glycosylation) and FV₂ (without). FV₁ was shown to have decreased binding affinity for negatively charged phospholipid membranes, decreased activity in the prothrombinase complex, and reduced sensitivity to inactivation by APC (86–89). Furthermore, FV₁ had significantly reduced activity as APC anticoagulant cofactor, both in plasma clotting assays and in the setting of a purified FVIIIa inactivation assay (51). These studies indicate that the anticoagulant cofactor function of FV is phospholipid-dependent.

Mutation of Ile at position 359 in FV to Thr (FV_{Liverpool}) (48) creates a glycosylation consensus sequence for glycosylation at N357. The presence of a bulky carbohydrate at this position was shown to inhibit R306 cleavage in FVa, but did not affect cleavage at R506 in FVa (90). Furthermore, FV_{Liverpool} showed no anticoagulant cofactor activity for APC/protein S in the inactivation of FVIIIa in a purified assay (90). Whether R506 cleavage, which is required for the anticoagulant cofactor activity, is affected in FV_{Liverpool} is currently unknown. The three-dimensional-structure model of FVa (91) shows that N357 is located on the 'backside' of the FV heavy chain and is therefore relatively distant from R306 and R506.

The FV R2 haplotype may affect anticoagulant activity of FV

The FV R2 haplotype represents a collection of mutations in the FV gene, M385T (92), H1299R (93), M1736V (94), and D2194G (92), which may be related to reduced levels of FV in plasma (93, 95–97) and mild resistance to APC (40, 98, 99) in homozygous carriers. The mechanisms behind this are not clear, as in heterozygous carriers neither FV levels nor APC sensitivity ratio appeared reduced (95, 98, 100, 101). Possibly in conjunction with R506Q-FV in the same patient the heterozygous FV R2 haplotype may contribute to a reduction in APC sensitivity (95, 98, 100, 102). Furthermore, a meta-analysis of patient-based studies was not conclusive about the effect of the FV R2 haplotype variant for risk of thrombosis either by itself, or in conjunction with R506Q-FV (103). The FV R2 haplotype was also observed to have reduced anticoagulant function for APC in plasma based assays (40, 99). However, this FV variant is also associated with a reduced FV₂:FV₁ ratio (92, 104), resulting in a relative increase of FV₁ concentration which is the FV form with reduced anticoagulant function and is the overall more thrombogenic form (86). This may contribute to the reduced anticoagulant activity of FV R2 derived from plasma (105). Yamazaki et al. (96) showed that the H1299R mutation, which is prevalent in the FV R2 haplotype, results in impaired glycosylation of the C-terminal part of the B domain of FV, an area

which is required of the FV anticoagulant activity. Although the glycosylation of FV in relation to the anticoagulant function has not been formally investigated, this may be an indication of the importance of glycosylation in this part of the molecule.

Platelet derived FV may not have anticoagulant activity

In the blood, 20–25% of total FV is stored in alpha-granules of platelets (106). Platelet FV originates from plasma FV that is taken up by megakaryocytes, after which it undergoes additional posttranslational modification, distinguishing it from plasma FV (107–109). Most of the platelet FV pool is partially activated by cleavage at T1543 (107, 110). As an intact connection between the B domain and the light chain is required for FV anticoagulant function (29, 56), it is unlikely that platelet FV has any anticoagulant cofactor properties toward APC. However, to our knowledge no studies have been done that investigate platelet derived FV/FVa as an anticoagulant cofactor for APC/protein S.

Conclusion

The functional properties of the FV anticoagulant effect have been well characterised, but structural and mechanistic properties remain to be further explored. It is presently not known how cleavage at R506 changes the conformation of the FV molecule, or how anticoagulant FV interacts with the APC/protein S/substrate complex. Elucidation of these characteristics may have important therapeutic implications, for example a FV-based molecule with only anticoagulant properties may be of great benefit for patients that carry the FV_{Leiden} mutation.

Conflict of interest

None declared.

References

1. Owren PA. Parahaemophilia; haemorrhagic diathesis due to absence of a previously unknown clotting factor. *Lancet* 1947; 1: 446–448.
2. Stormorken H. The discovery of factor V: a tricky clotting factor. *J Thromb Haemost* 2003; 1: 206–213.
3. Dahlbäck B, et al. Familial thrombophilia due to a previously unrecognized mechanism characterized by poor anticoagulant response to activated protein C: Prediction of a cofactor to activated protein C. *Proc Natl Acad Sci USA* 1993; 90: 1004–1008.
4. Bertina RM, et al. Mutation in blood coagulation factor V associated with resistance to activated protein C. *Nature* 1994; 369: 64–67.
5. Dahlbäck B, Hildebrand B. Inherited resistance to activated protein C is corrected by anticoagulant cofactor activity found to be a property of factor V. *Proc Natl Acad Sci U S A* 1994; 91: 1396–1400.
6. Kalafatis M, et al. The mechanism of inactivation of human factor V and human factor Va by activated protein C. *J Biol Chem* 1994; 269: 31869–31880.

7. Fay PJ, et al. Activated protein C-catalyzed inactivation of human factor VIII and factor VIIIa. Identification of cleavage sites and correlation of proteolysis with cofactor activity. *J Biol Chem* 1991; 266: 20139–20145.
8. Nicolaes GA, et al. Peptide bond cleavages and loss of functional activity during inactivation of factor Va and factor VaR506Q by activated protein C. *J Biol Chem* 1995; 270: 21158–21166.
9. Fay PJ, et al. Human factor VIIIa subunit structure. Reconstruction of factor VIIIa from the isolated A1/A3-C1-C2 dimer and A2 subunit. *J Biol Chem* 1991; 266: 8957–8962.
10. Fay PJ, Smudzin TM. Characterization of the interaction between the A2 subunit and A1/A3-C1-C2 dimer in human factor VIIIa. *J Biol Chem* 1992; 267: 13246–13250.
11. Gale AJ, et al. Detailed mechanisms of the inactivation of factor VIIIa by activated protein C in the presence of its cofactors, protein S and factor V. *J Biol Chem* 2008; 283: 16355–16362.
12. Norström EA, et al. Importance of protein S and phospholipid for activated protein C-mediated cleavages in factor Va. *J Biol Chem* 2003; 278: 24904–24911.
13. Rosing J, et al. Effects of protein S and factor Xa on peptide bond cleavages during inactivation of factor Va and factor Va^{R506Q} by activated protein C. *J Biol Chem* 1995; 270: 27852–27858.
14. Yegneswaran S, et al. Protein S alters the active site location of activated protein C above the membrane surface. A fluorescence resonance energy transfer study of topography. *J Biol Chem* 1997; 272: 25013–25021.
15. Yegneswaran S, et al. Relocating the active site of activated protein C eliminates the need for its protein S cofactor. A fluorescence resonance energy transfer study. *J Biol Chem* 1999; 274: 5462–5468.
16. Tran S, Dahlbäck B. Novel APC-cleavage sites in FVa provide insights into mechanisms of action of APC and its cofactor protein S. *J Thromb Haemost* 2010; 8: 129–136.
17. Cramer TJ, Gale AJ. Function of the activated protein C (APC) autolysis loop in activated FVIII inactivation. *Br J Haematol* 2011; 153: 644–654.
18. O'Brien LM, et al. Regulation of factor VIIIa by human activated protein C and protein S: inactivation of cofactor in the intrinsic factor Xase. *Blood* 2000; 95: 1714–1720.
19. Branson HE, et al. Inherited protein C deficiency and coumarin-responsive chronic relapsing purpura fulminans in a newborn infant. *Lancet* 1983; 2: 1165–1168.
20. Griffin JH, et al. Deficiency of protein C in congenital thrombotic disease. *J Clin Invest* 1981; 68: 1370–1373.
21. Esmon CT. The roles of protein C and thrombomodulin in the regulation of blood coagulation. *J Biol Chem* 1989; 264: 4743–4746.
22. Griffin JH, et al. Anticoagulant protein C pathway defective in majority of thrombophilic patients. *Blood* 1993; 82: 1989–1993.
23. Svensson PJ, Dahlbäck B. Resistance to activated protein C as a basis for venous thrombosis. *N Engl J Med* 1994; 330: 517–522.
24. Koster T, et al. Venous thrombosis due to poor anticoagulant response to activated protein C: Leiden Thrombophilia Study. *Lancet* 1993; 342: 1503–1506.
25. Cadroy Y, et al. Frequency of a defective response to activated protein C in patients with a history of venous thrombosis. *Blood* 1994; 83: 2008–2009.
26. Sun X, et al. Blood coagulation factor Va abnormality associated with resistance to activated protein C in venous thrombophilia. *Blood* 1994; 83: 3120–3125.
27. Zöller B, et al. Identification of the same factor V gene mutation in 47 out of 50 thrombosis-prone families with inherited resistance to activated protein C. *J Clin Invest* 1994; 94: 2521–2524.
28. Heeb MJ, et al. Activated protein C resistance: molecular mechanisms based on studies using purified Gln506-factor V. *Blood* 1995; 85: 3405–3411.
29. Shen L, Dahlbäck B. Factor V and protein S as synergistic cofactors to activated protein C in degradation of factor VIIIa. *J Biol Chem* 1994; 269: 18735–18738.
30. Rosendaal FR, et al. High risk of thrombosis in patients homozygous for factor V Leiden (activated protein C resistance). *Blood* 1995; 85: 1504–1508.
31. Castoldi E, et al. Molecular bases of pseudo-homozygous APC resistance: the compound heterozygosity for FV R506Q and a FV null mutation results in the exclusive presence of FV Leiden molecules in plasma. *Thromb Haemost* 1998; 80: 403–406.
32. Greengard JS, et al. Pseudo-homozygous activated protein C resistance due to coinheritance of heterozygous factor V R506Q and type I factor V deficiency associated with thrombosis. *Thromb Haemost* 1995; 73: 1361 Abstract.
33. Guasch JF, et al. Molecular characterization of a type I quantitative factor V deficiency in a thrombosis patient that is "pseudo homozygous" for activated protein C resistance. *Thromb Haemost* 1997; 77: 252–257.
34. Simioni P, et al. "Pseudo homozygous" activated protein C resistance due to double heterozygous factor V defects (factor V Leiden mutation and type I quantitative factor V defect) associated with thrombosis: report of two cases belonging to two unrelated kindreds. *Thromb Haemost* 1996; 75: 422–426.
35. Zehnder JL, Jain M. Recurrent thrombosis due to compound heterozygosity for factor V Leiden and factor V deficiency. *Blood Coagul Fibrinolysis* 1996; 7: 361–362.
36. Brugge JM, et al. Expression of the normal factor V allele modulates the APC resistance phenotype in heterozygous carriers of the factor V Leiden mutation. *J Thromb Haemost* 2005; 3: 2695–2702.
37. Simioni P, et al. An underestimated combination of opposites resulting in enhanced thrombotic tendency. *Blood* 2005; 106: 2363–2365.
38. Acharya SS, et al. Rare Bleeding Disorder Registry: deficiencies of factors II, V, VII, X, XIII, fibrinogen and dysfibrinogenemias. *J Thromb Haemost* 2004; 2: 248–256.
39. Duckers C, et al. Factor V Leiden pseudo-homozygotes have a more pronounced hypercoagulable state than factor V Leiden homozygotes. *J Thromb Haemost* 2011; 9: 864–867.
40. Castoldi E, et al. Impaired APC cofactor activity of factor V plays a major role in the APC resistance associated with the factor V Leiden (R506Q) and R2 (H1299R) mutations. *Blood* 2004; 103: 4173–4179.
41. Zivelin A, et al. Prothrombin 20210G>A is an ancestral prothrombotic mutation that occurred in whites approximately 24,000 years ago. *Blood* 2006; 107: 4666–4668.
42. Chan WP, et al. A novel mutation of Arg306 of factor V gene in Hong Kong Chinese. *Blood* 1998; 91: 1135–1139.
43. Williamson D, et al. Factor V Cambridge: A new mutation (Arg³⁰⁶->Thr) associated with resistance to activated protein C. *Blood* 1998; 91: 1140–1144.
44. Liang R, et al. Clinical significance of Arg306 mutations of factor V gene. *Blood* 1998; 92: 2599–2600.
45. Van der Neut Kolfschoten M, et al. The activated protein C (APC)-resistant phenotype of APC cleavage site mutants of recombinant factor V in a reconstituted plasma model. *Blood Coagul Fibrinolysis* 2002; 13: 207–215.
46. Norström E, et al. Functional characterization of recombinant FV Hong Kong and FV Cambridge. *Blood* 2002; 100: 524–530.
47. Cai H, et al. A novel mutation (g2172->c) in the factor v gene in a chinese family with hereditary activated protein C resistance. *Thromb Res* 2010; 125: 545–548.
48. Mumford AD, et al. Factor V I359T: a novel mutation associated with thrombosis and resistance to activated protein C. *Br J Haematol* 2003; 123: 496–501.
49. Dahlbäck B. The discovery of activated protein C resistance. *J Thromb Haemost* 2003; 1: 3–9.
50. Lu D, et al. Comparison of activated protein C/protein S-mediated inactivation of human factor VIII and factor V. *Blood* 1996; 87: 4708–4717.
51. Váradi K, et al. Factor V enhances the cofactor function of protein S in the APC-mediated inactivation of factor VIII: influence of the factor VR506Q mutation. *Thromb Haemost* 1996; 76: 208–214.
52. Thorelli E, et al. Cleavage of factor V at Arg 506 by activated protein C and the expression of anticoagulant activity of factor V. *Blood* 1999; 93: 2552–2558.
53. Cramer TJ, et al. Factor V is an anticoagulant cofactor for activated protein C during inactivation of factor Va. *Pathophysiol Haemost Thromb* 2010; 37: 17–23.
54. Pipe SW, et al. Mild hemophilia A caused by increased rate of factor VIII A2 subunit dissociation: evidence for nonproteolytic inactivation of factor VIIIa in vivo. *Blood* 1999; 93: 176–183.
55. Kalafatis M, et al. Characterization of the molecular defect in factor VR506Q. *J Biol Chem* 1995; 270: 4053–4057.
56. Thorelli E, et al. The C-terminal region of the factor V B-domain is crucial for the anticoagulant activity of factor V. *J Biol Chem* 1998; 273: 16140–16145.
57. Jenny RJ, et al. Complete cDNA and derived amino acid sequence of human factor V. *Proc Natl Acad Sci USA* 1987; 84: 4846–4850.
58. Kane WH, Davie EW. Cloning of a cDNA coding for human factor V, a blood coagulation factor homologous to factor VIII and ceruloplasmin. *Proc Natl Acad Sci USA* 1986; 83: 6800–6804.
59. Gershagen S, et al. A cDNA coding for human sex hormone binding globulin. Homology to vitamin K-dependent protein S. *FEBS Lett* 1987; 220: 129–135.
60. Lundwall A, et al. Isolation and sequence of the cDNA for human protein S, a regulator of blood coagulation. *Proc Natl Acad Sci USA* 1986; 83: 6716–6720.
61. Harmon S, et al. Dissociation of activated protein C functions by elimination of protein S cofactor enhancement. *J Biol Chem* 2008; 283: 30531–30539.
62. Preston RJ, et al. Multifunctional specificity of the protein C/activated protein C Gla domain. *J Biol Chem* 2006; 281: 28850–28857.

63. Smirnov MD, et al. A chimeric protein C containing the prothrombin Gla domain exhibits increased anticoagulant activity and altered phospholipid specificity. *J Biol Chem* 1998; 273: 9031–9040.
64. Andersson HM, et al. Activated protein C cofactor function of protein S: a critical role for Asp95 in the EGF1-like domain. *Blood* 2010; 115: 4878–4885.
65. Saller F, et al. The gamma-carboxyglutamic acid domain of anticoagulant protein S is involved in activated protein C cofactor activity, independently of phospholipid binding. *Blood* 2005; 105: 122–130.
66. He X, et al. Amino acid residues in thrombin-sensitive region and first epidermal growth factor domain of vitamin K-dependent protein S determining specificity of the activated protein C cofactor function. *J Biol Chem* 1998; 273: 27449–27458.
67. Chang GT, et al. Construction and characterization of thrombin-resistant variants of recombinant human protein S. *Thromb Haemost* 1994; 72: 693–697.
68. Dahlbäck B, et al. Characterization of functionally important domains in human vitamin K-dependent protein S using monoclonal antibodies. *J Biol Chem* 1990; 265: 8127–8135.
69. Long GL, et al. Human protein S cleavage and inactivation by coagulation factor Xa. *J Biol Chem* 1998; 273: 11521–11526.
70. Hackeng TM, et al. Conformational changes in activated protein C caused by binding of the first epidermal growth factor-like module of protein S. *Biochem J* 2000; 349: 757–764.
71. Mille-Baker B, et al. Deletion or replacement of the second EGF-like domain of protein S results in loss of APC cofactor activity. *Blood* 2003; 101: 1416–1418.
72. Stenberg Y, et al. Characterization of recombinant epidermal growth factor (EGF)-like modules from vitamin-K-dependent protein S expressed in *Spodoptera cells*—the cofactor activity depends on the N-terminal EGF module in human protein S. *Eur J Biochem* 1998; 251: 558–564.
73. Dahlbäck B, et al. High affinity interaction between C4b-binding protein and vitamin K-dependent protein S in the presence of calcium. Suggestion of a third component in blood regulating the interaction. *J Biol Chem* 1990; 265: 16082–16087.
74. Hillarp A, Dahlbäck B. Novel subunit in C4b-binding protein required for protein S binding. *J Biol Chem* 1988; 263: 12759–12764.
75. Schwälbe R, et al. Assembly of protein S and C4b-binding protein on membranes. *J Biol Chem* 1990; 265: 16074–16081.
76. Fernández JA, et al. Identification of residues 413–433 of plasma protein S as essential for binding to C4b-binding protein. *J Biol Chem* 1993; 268: 16788–16794.
77. Fernández JA, et al. Involvement of amino acid residues 423–429 of human protein S in binding to C4b-binding protein. *Blood Cells Mol Dis* 1998; 24: 101–112.
78. Linse S, et al. A region of vitamin K-dependent protein S that binds to C4b binding protein (C4BP) identified using bacteriophage peptide display libraries. *J Biol Chem* 1997; 272: 14658–14665.
79. Maurissen LF, et al. Re-evaluation of the role of the protein S-C4b binding protein complex in activated protein C-catalyzed factor Va-inactivation. *Blood* 2008; 111: 3034–3041.
80. Van de Poel RH, et al. C4b-binding protein inhibits the factor V-dependent but not the factor V-independent cofactor activity of protein S in the activated protein C-mediated inactivation of factor VIIIa. *Thromb Haemost* 2001; 85: 761–765.
81. Van Wijnen M, et al. Characterization of mini-protein S, a recombinant variant of protein S that lacks the sex hormone binding globulin-like domain. *Biochem J* 1998; 330 (Pt 1): 389–396.
82. Nyberg P, et al. The SHBG-like region of protein S is crucial for factor V-dependent APC-cofactor function. *FEBS Lett* 1998; 433: 28–32.
83. Kane WH, et al. Cloning of cDNAs coding for the heavy chain region and connecting region of human factor V, a blood coagulation factor with four types of internal repeats. *Biochemistry* 1987; 26: 6508–6514.
84. Fernández JA, et al. The carbohydrate moiety of factor V modulates inactivation by activated protein C. *Blood* 1997; 89: 4348–4354.
85. Silveira JR, et al. Carbohydrate moieties on the procofactor factor V, but not the derived cofactor factor Va, regulate its inactivation by activated protein C. *Biochemistry* 2002; 41: 1672–1680.
86. Hoekema L, et al. Human factor Va1 and factor Va2: properties in the procoagulant and anticoagulant pathways. *Biochemistry* 1997; 36: 3331–3335.
87. Rosing J, et al. Characterization of two forms of human factor Va with different cofactor activities. *J Biol Chem* 1993; 268: 21130–21136.
88. Kim SW, et al. Partial glycosylation at asparagine-2181 of the second C-type domain of human factor V modulates assembly of the prothrombinase complex. *Biochemistry* 1999; 38: 11448–11454.
89. Nicolaes GAF, et al. Partial glycosylation of Asn2181 in human factor V as a cause of molecular and functional heterogeneity. Modulation of glycosylation efficiency by mutagenesis of the consensus sequence for N-linked glycosylation. *Biochemistry* 1999; 38: 13584–13591.
90. Steen M, et al. Functional characterization of Factor V-Ile359Thr, a novel mutation associated with thrombosis. *Blood* 2004; 103: 3381–3387.
91. Autin L, et al. Proposed structural models of the prothrombinase (FXa-FVa) complex. *Proteins* 2006; 63: 440–450.
92. Castoldi E, et al. Mutations in the R2 FV gene affect the ratio between the two FV isoforms in plasma. *Thromb Haemost* 2000; 83: 362–365.
93. Lunghi B, et al. Detection of new polymorphic markers in the factor V gene: association with factor V levels in plasma. *Thromb Haemost* 1996; 75: 45–48.
94. Bayston TA, et al. A polymorphism in the human coagulation factor V gene. *Hum Mol Genet* 1994; 3: 2085.
95. De Visser MC, et al. The HR2 haplotype of factor V: effects on factor V levels, normalized activated protein C sensitivity ratios and the risk of venous thrombosis. *Thromb Haemost* 2000; 83: 577–582.
96. Yamazaki T, et al. Molecular basis of quantitative factor V deficiency associated with factor V R2 haplotype. *Blood* 2002; 100: 2515–2521.
97. Castaman G, et al. Phenotypic homozygous activated protein C resistance associated with compound heterozygosity for Arg506Gln (factor V Leiden) and His1299Arg substitutions in factor V. *Br J Haematol* 1997; 99: 257–261.
98. Bernardi F, et al. A factor V genetic component differing from factor V R506Q contributes to the activated protein C resistance phenotype. *Blood* 1997; 90: 1552–1557.
99. Hoekema L, et al. Functional properties of factor V and factor Va encoded by the R2-gene. *Thromb Haemost* 2001; 85: 75–81.
100. Castaman G, et al. Heterogeneity of activated protein C resistance phenotype in subjects with compound heterozygosity for HR2 haplotype and FV Leiden mutation (R506Q) in factor V gene. *Thromb Haemost* 2000; 84: 357–358.
101. Luddington R, et al. The factor V R2 allele: risk of venous thromboembolism, factor V levels and resistance to activated protein C. *Thromb Haemost* 2000; 83: 204–208.
102. Faioli EM, et al. Coinheritance of the HR2 haplotype in the factor V gene confers an increased risk of venous thromboembolism to carriers of factor V R506Q (factor V Leiden). *Blood* 1999; 94: 3062–3066.
103. Castaman G, et al. The factor V HR2 haplotype and the risk of venous thrombosis: a meta-analysis. *Haematologica* 2003; 88: 1182–1189.
104. Yamazaki T, et al. The D2194G mutation is responsible for increased levels of FV1 in carriers of the factor V R2 haplotype. *Thromb Haemost* 2010; 104: 860–861.
105. Govers-Riemslog JW, et al. Reduced factor V concentration and altered FV1/FV2 ratio do not fully explain R2-associated APC-resistance. *Thromb Haemost* 2002; 88: 444–449.
106. Tracy PB, et al. Radioimmunoassay of factor V in human plasma and platelets. *Blood* 1982; 60: 59–63.
107. Gould WR, et al. Unique in vivo modifications of coagulation factor V produce a physically and functionally distinct platelet-derived cofactor: characterization of purified platelet-derived factor V/Va. *J Biol Chem* 2004; 279: 2383–2393.
108. Gould WR, et al. Megakaryocytes endocytose and subsequently modify human factor V in vivo to form the entire pool of a unique platelet-derived cofactor. *J Thromb Haemost* 2005; 3: 450–456.
109. Camire RM, et al. Secretable human platelet-derived factor V originates from the plasma pool. *Blood* 1998; 92: 3035–3041.
110. Østerud B, et al. Factor V activity of platelets: evidence for an activated factor V molecule and for a platelet activator. *Blood* 1977; 49: 819–834.